

Ersatzteilliste
Spare parts list
Liste des pièces de rechange



TW 300 S

Sprühextraktions-Maschine
Spray extractors-machine
Injecteur-extracteurs-automates



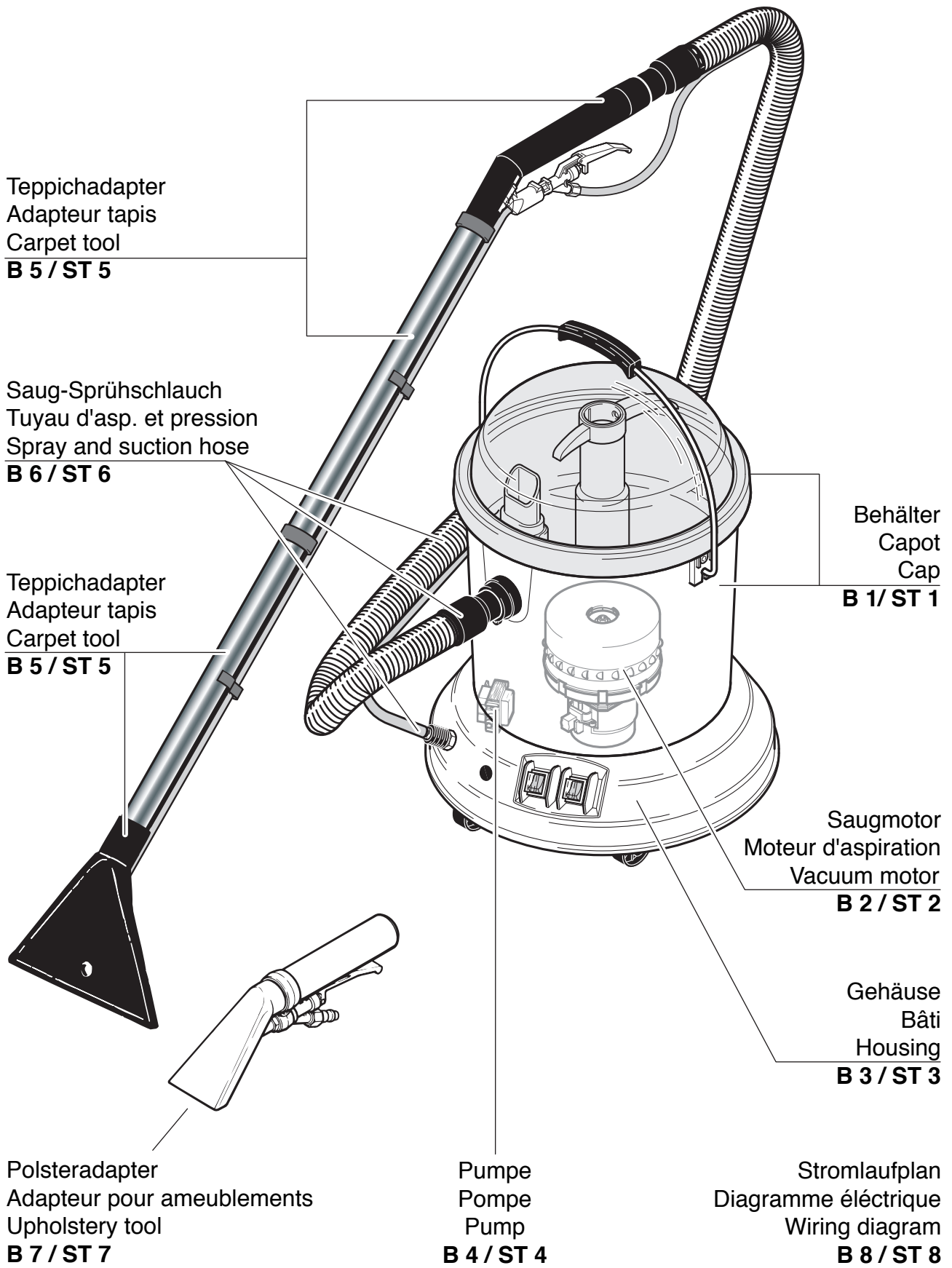

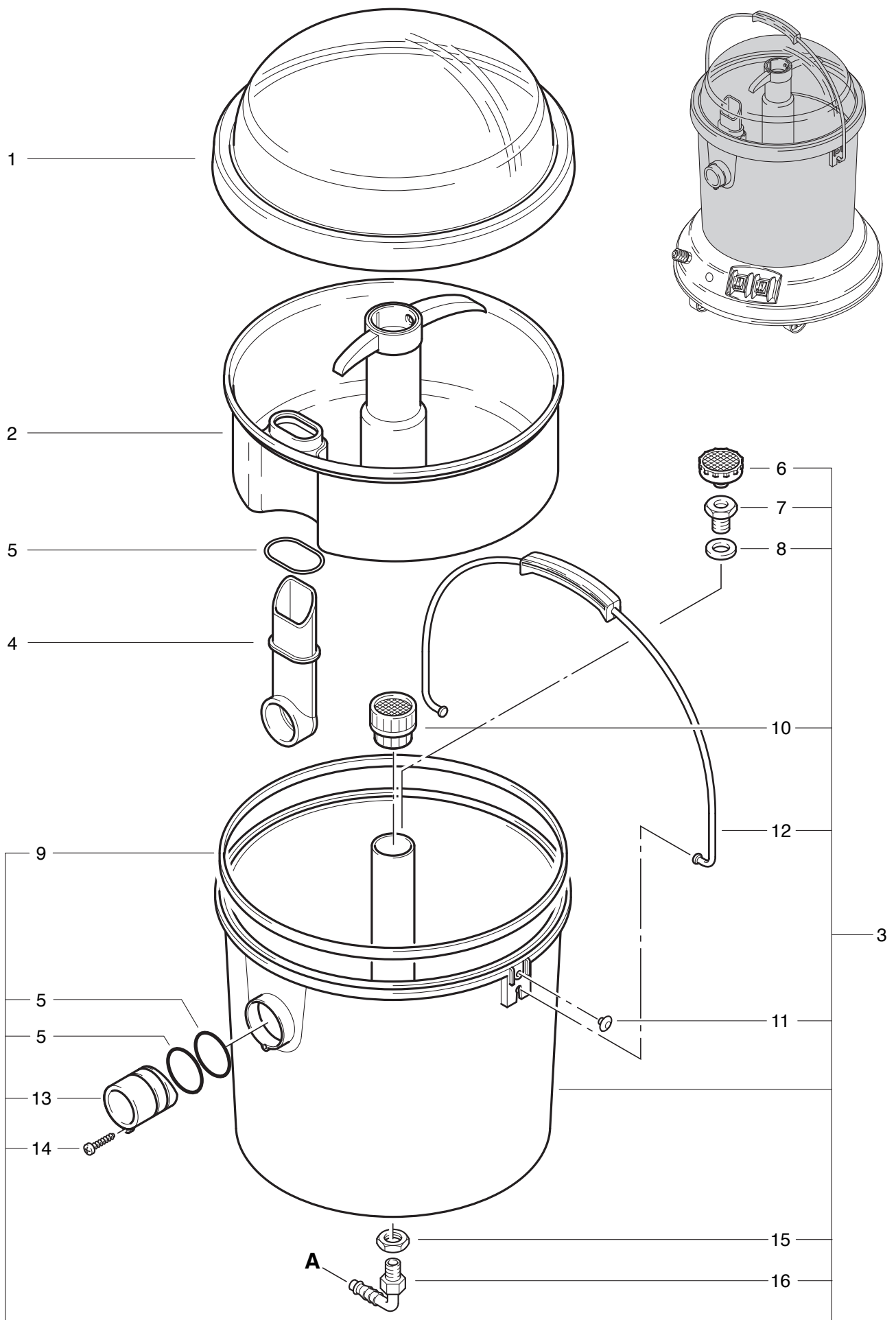

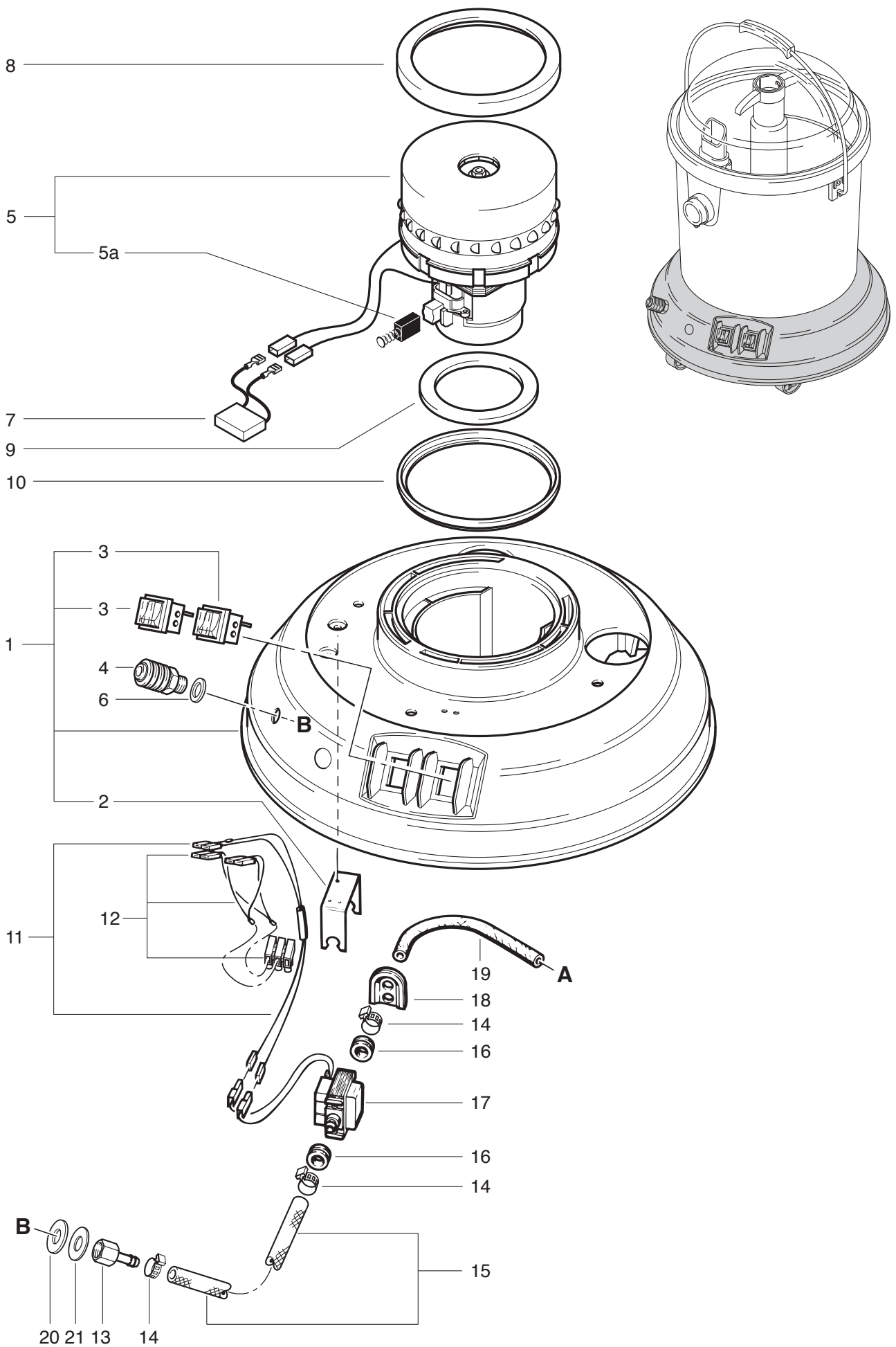

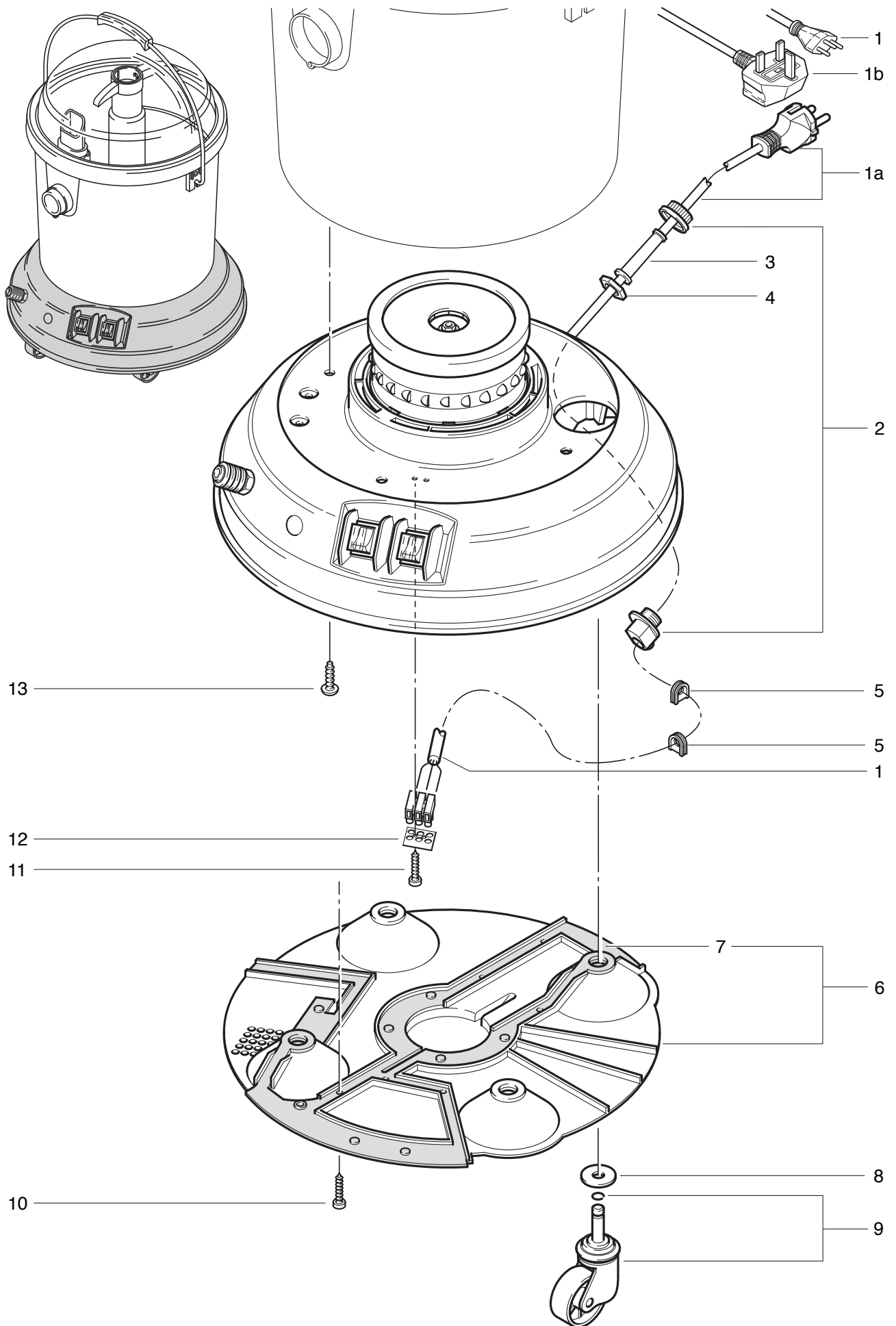

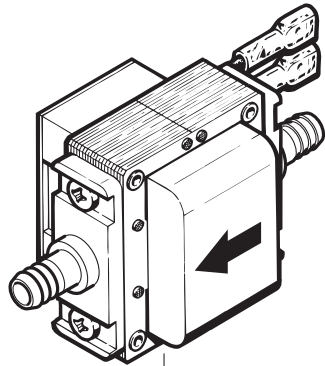

1

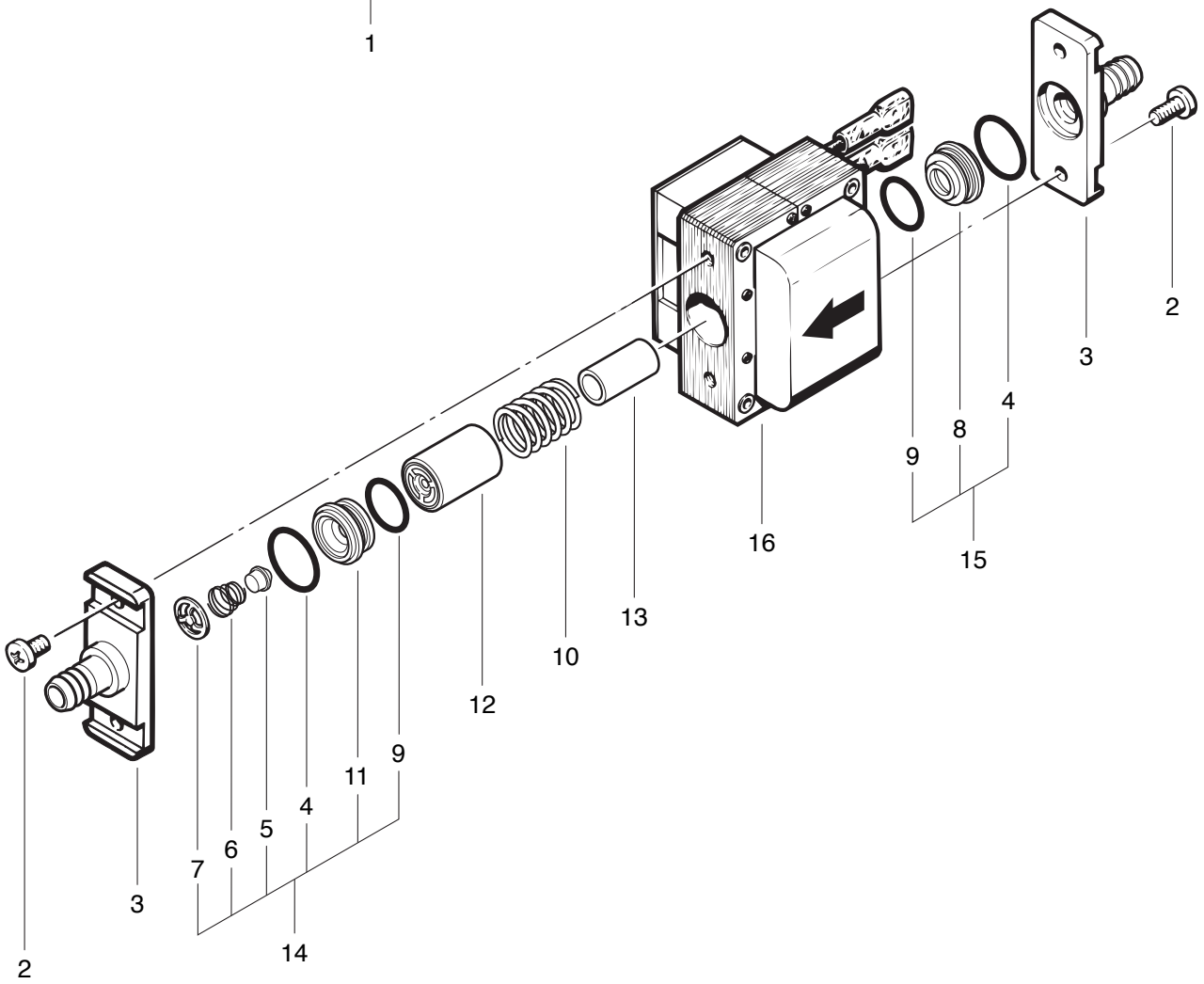

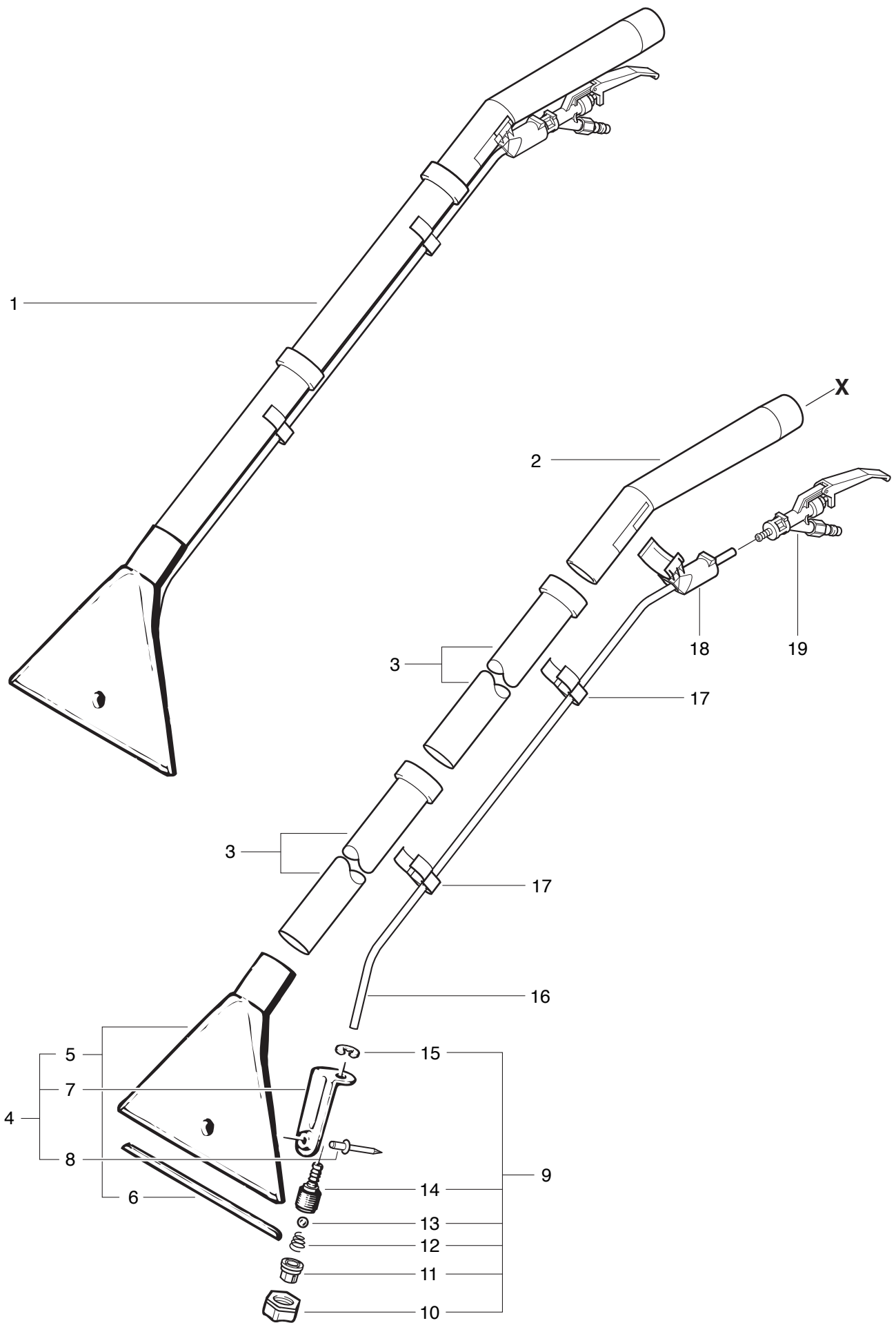

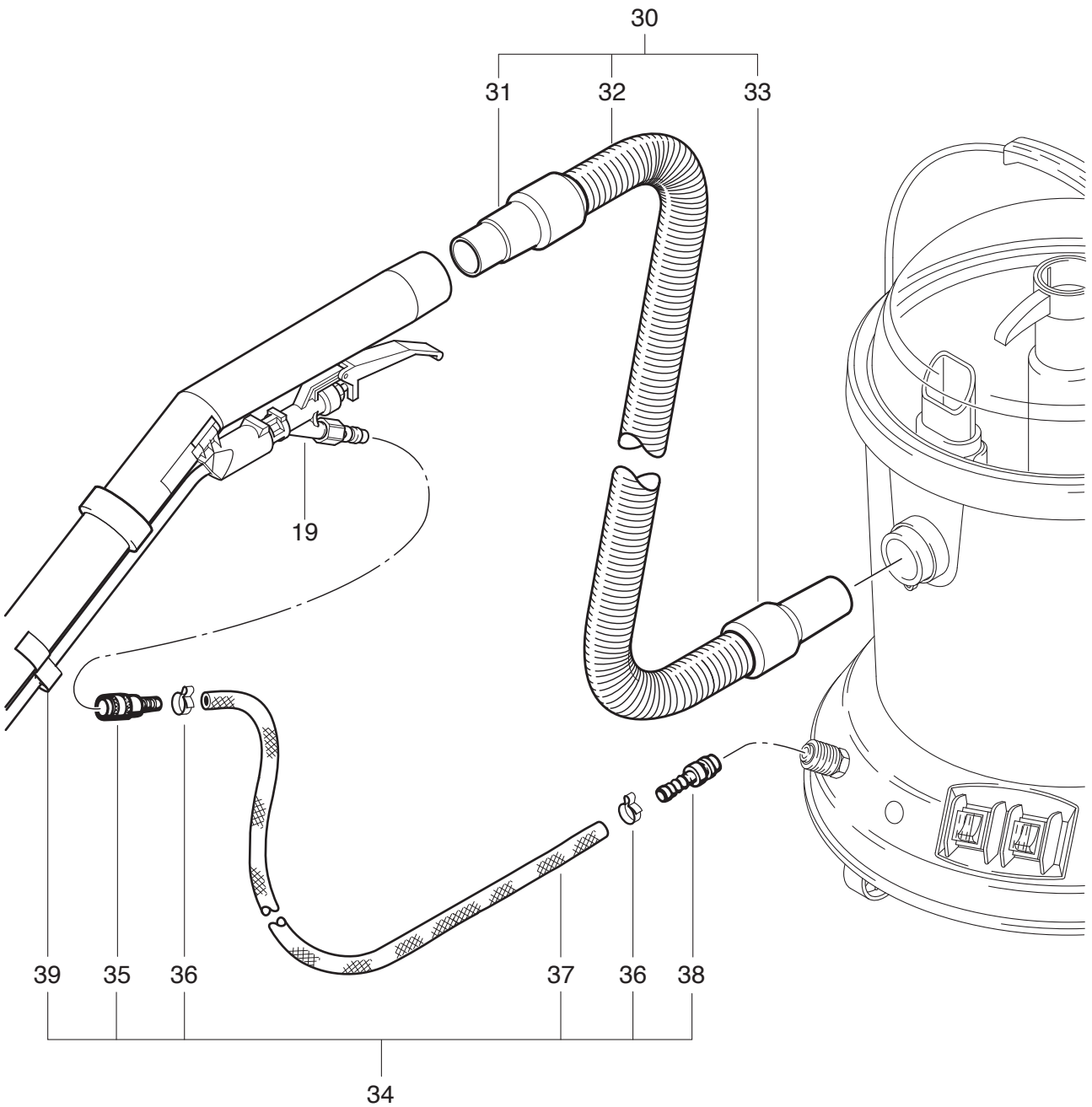
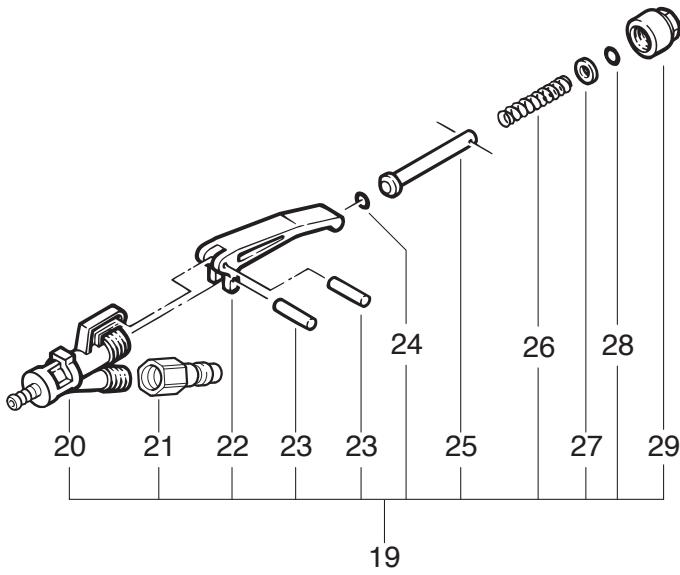

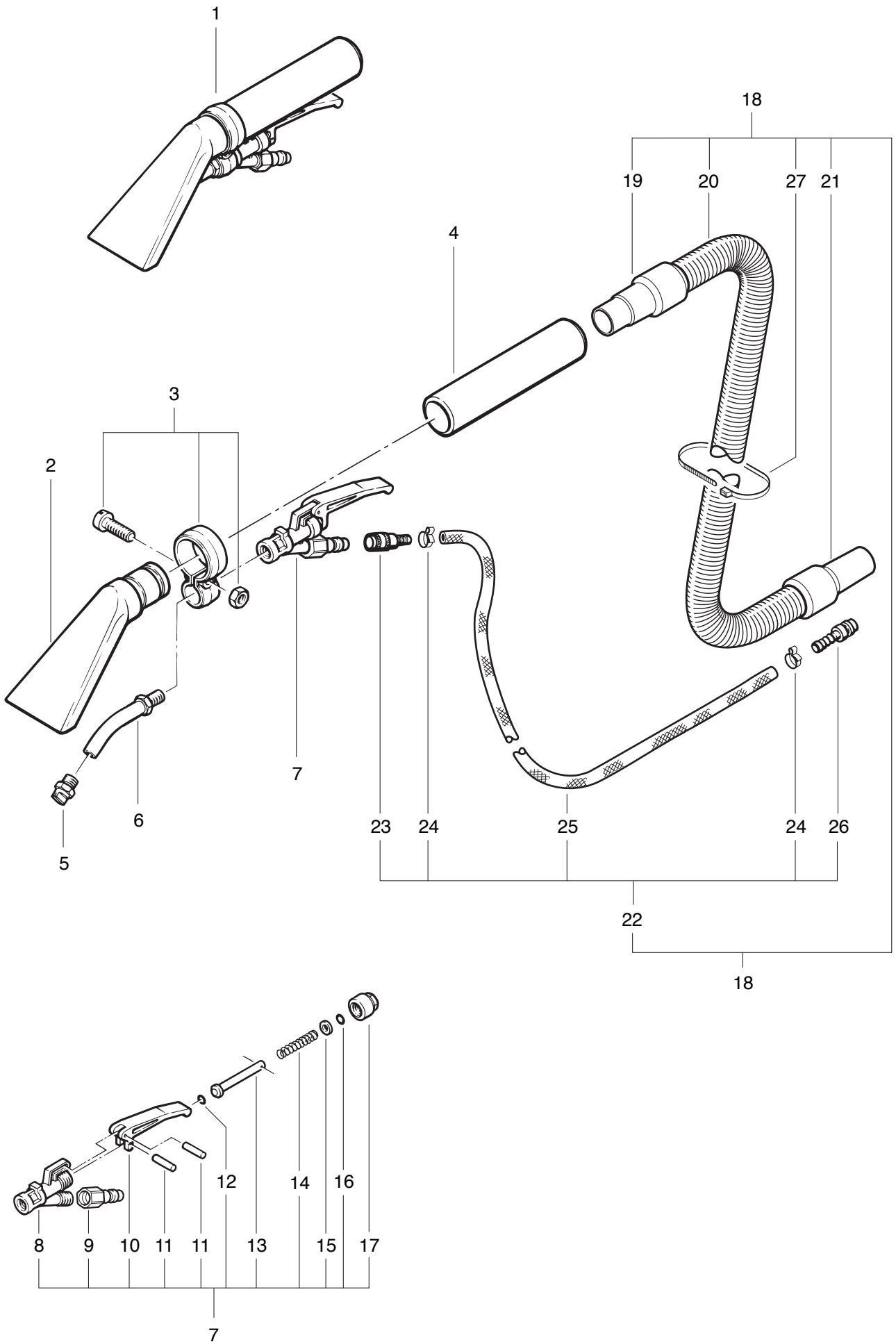

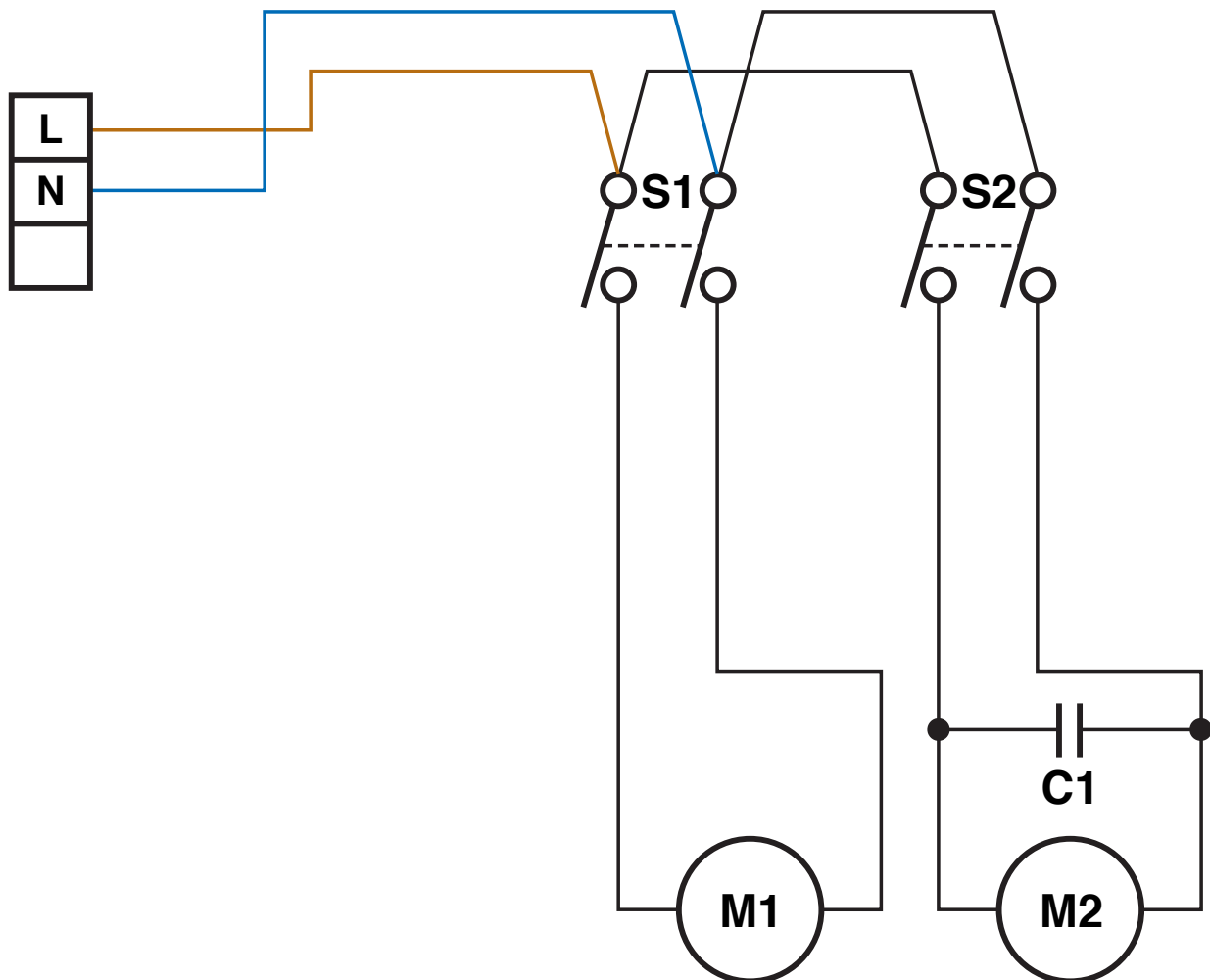

S1 = Schalter 1 / Interrupteur 1 / Tumbler switch 1

S2 = Schalter 2 / Interrupteur 2 / Tumbler switch 2

C1 = Entstörkondensator 0,1 F / Condensateur 0,1 F / Capacitor 0,1 F

M1 = Pumpe / Pompe / Pump

M2 = Saugmotor LAMB, 750 W / Motuer d'aspiration 750 W, LAMB / Vacuum motor 750 W, LAMB

M2 = Saugmotor OEP, 1000 W / Motuer d'aspiration 1000 W, OEP / Vacuum motor 1000 W, OEP